

# Model 482

## High Gain Thermally Compensated Pyroelectric IR Detector



Manufactured under one or more of the following U.S. patents: 3,839,640 - 4,218,620 - 4,326,663 - 4,384,207 - 4,437,003 - 4,441,023 - 4,523,095

**Model 482** consists of two lithium tantalate sensing elements, a load resistor and a JFET sealed into a TO-18 transistor package with an optical filter.

One centrally located sensing element is exposed to infrared radiation entering through the optical filter while the second element is shielded from outside radiation.

The sensing elements are connected electrically in a parallel opposed configuration for cancellation of signals generated by both crystals due to thermal changes in the housing environment.

The JFET circuit is configured to provide gain (about 5x with a 100k  $\Omega$  source resistor) whereas the standard source follower circuit has a gain less than one.

A source resistor is required to set the drain current and the operating parameters of the JFET. A 100k  $\Omega$  to 1 M  $\Omega$  resistor is recommended. This resistor should be a low noise metal film type.

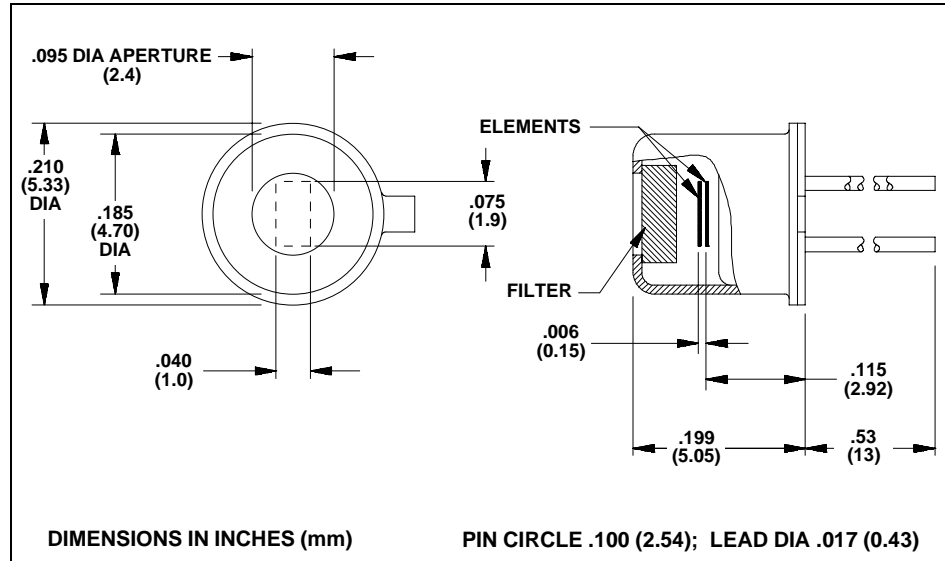

Characteristics	482	Unit	Test Conditions	ELTECdata Reference
Detector Type	POD			
Element Size <sup>1</sup>	1.0 x 1.9	mm, each		
Optical Bandwidth	0.1 to 1,000	$\mu\text{m}$	Various Filters	101
Responsivity (typ)	8,850	V/W	8 to 14 $\mu\text{m}$ , 1 Hz	
Noise (typ)	12	$\mu\text{Vrms}/\sqrt{\text{Hz}}$	1 Hz, 1 Hz BW	
NEP (typ)	$1.4 \times 10^{-9}$	$\text{W}/\sqrt{\text{Hz}}$	8 to 14 $\mu\text{m}$ , 1 Hz, 1 Hz BW	100
D* (typ)	$1.0 \times 10^8$	$\text{cm}\sqrt{\text{Hz}}/\text{W}$	8 to 14 $\mu\text{m}$ , 1 Hz, 1 Hz BW	100
Operating Voltage (min)	5	VDC	V+ to Gnd	104
Operating Voltage (max)	10			(4.1.c)
Operating Current (min)	8	$\mu\text{A}$	$R_S = 100\text{k } \Omega$	104
Operating Current (max)	30			(4.1.c)
Offset Voltage (min)	0.8	V	$R_S = 100\text{k } \Omega$	106
Offset Voltage (max)	3.0			Section B
Output Impedance	$<R_S$	$\Omega$		
Thermal Breakpoint $f_T$ (typ)	0.2	Hz		102
Recommended Operating Temperature	-40 to +70	$^{\circ}\text{C}$	Functional	
Storage Temperature	-55 to +125	$^{\circ}\text{C}$	$\Delta T < 50^{\circ}\text{C}/\text{min}$	
Output Protection	Do not exceed a maximum drain current of 2 mA			

Characteristics at 25 $^{\circ}\text{C}$ , with -3 filter, V+ = 5 VDC,  $R_S = 100\text{k } \Omega$  unless otherwise stated. Data is established on a sample basis and is believed to be representative.

<sup>1</sup>Dual elements, over under configuration with 1 element shielded from incident light.

## Applications

- Industrial Control
- Object Counting
- Infrared Telescopes
- Robotics
- Motion Sensing
- Intruder Detection
- Conveyor Monitoring

For best results, the following precautions and recommendations should be observed. (See ELTECdata #101):

**Mounting:** Avoid mechanical stresses on case and leads.

**Soldering:** Detectors must be hand soldered to minimize the chance of destroying the internal components. Avoid machine or hot air soldering. Leave a minimum lead length of .250 inch (6.35mm). When soldering to detector leads, use a heat sink between the case and leads. Beware that the new RoHS compliant solders require a higher soldering temperature making heat sinking the detector extremely important.

**Static Discharge:** Protect detectors from electrostatic charges.

**Thermal Shock:** Temperature changes and rate of change must be kept to a minimum (<50C°/min.) to prevent damage.

**Noise:** As a resolution or lower information limit, noise is established not only by the detector. Other noise sources are:

- Radiated and conducted RF signals
- Subsequent amplification or signal conditioning stages
- Power supply noise
- Components, such as high value resistors and capacitors (tantalum and aluminum electrolytic)
- Mechanical contacts and weak solder joints
- Shock and vibration excited microphonics
- Outside thermal influences on the detector other than the desired infrared input, i.e. drafts. (The Model 482 is less sensitive to drafts than single element detectors)

All of these noise sources should be considered carefully when the information signal is <1mV.

**Light Leakage:** Slight sensitivity to visible light leaking through the glass-to-metal seal on the base may be observed.

**Optical Design:** Use of a detector with a filter in an optical system may require consideration of the image displacement toward the filter. This displacement (s) caused by the insertion of a planoparallel plate (filter thickness = t; refractive index = N) is given by  $s = (t/N)(N-1)$ .

### Transmission Characteristics of -3 Filter (HP-7)

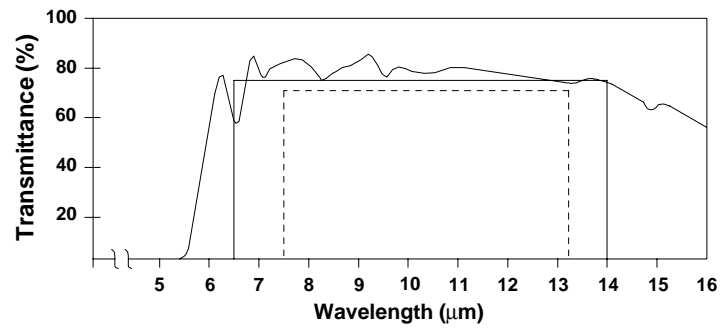

75% Transmission Average      70% Transmission Absolute  
Transmission below cutoff is <1%

For information on other standard filters available, refer to ELTECdata # 101.

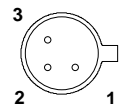
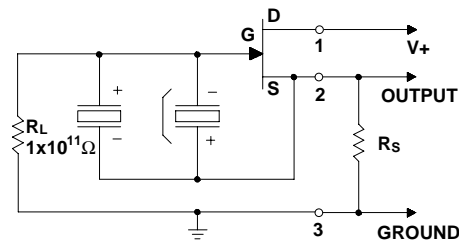

**BOTTOM VIEW**

#### PIN DESIGNATIONS

1. V +
2. OUTPUT
3. GND/CASE

**NOTICE:** The information provided herein is believed to be reliable. However, ELTEC Instruments, Inc. assumes no responsibility for inaccuracies or omissions. Due to industry components being incorporated into ELTEC's devices and ELTEC continually striving for product improvement, specifications may change without notice.



**Worldwide Eltec Product Distribution and Free Technical Support:**  
Silverlight Ltd., Glaernischstrasse 59, CH-8712 Staefa, Switzerland  
info@silverlight.ch http://www.eltec.ch