

Model 481

Miniature Single Element Pyroelectric IR Detector With Source Follower



Manufactured under one or more of the following U.S. patents: 3,839,640 - 4,218,620 - 4,326,663 - 4,384,207 - 4,437,003 - 4,441,023 - 4,523,095

Model 481 contains a single lithium tantalate sensing element and a JFET source follower sealed into a standard TO-18 transistor package with an optical filter.

A patented element mounting technique is used to improve thermal time constant and reduce effects of microphony.

A source resistor is needed to set the drain current and consequently the operating parameters of the JFET. A 47kΩ or greater value resistor is recommended.

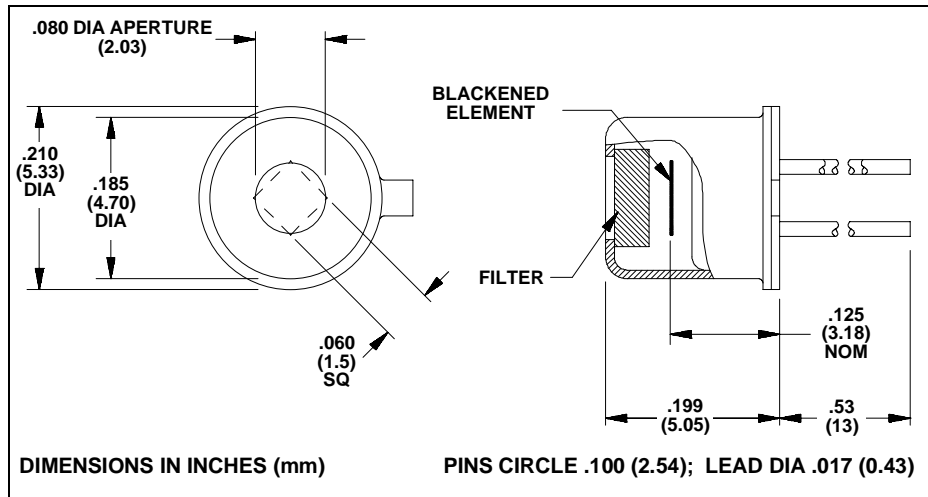

Applications

- Motion Sensing
- Lighting Control
- Intrusion Detection
- Industrial Control
- Gas Analysis
- Heating/AC Control
- Pyrometry
- Low-power Laser Detection
- Robotics
- Instrumentation

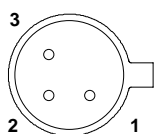
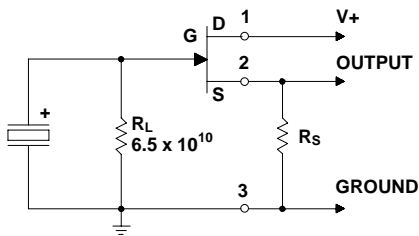

PIN DESIGNATIONS
 1. V+
 2. OUTPUT
 3. GND/CASE

BOTTOM VIEW

Characteristics	481	Unit	Test Conditions	ELTECdata Reference
Detector Type	Single			
Element Size	1.5 x 1.5	mm		
Optical Bandwidth	0.1 to 1,000	μm	Various Filters	101
Responsivity (min)	2,580	V/W	8 to 14 μm, 1Hz	
(typ)	3,110			
Noise (typ)	2.25	μVrms/√Hz	1Hz	
(max)	6.60			
NEP (typ)	7.21 x 10 ⁻¹⁰	W/√Hz	8 to 14 μm, 1Hz, 1Hz BW	100
(max)	2.56 x 10 ⁻⁹			
D* (min)	5.94 x 10 ⁷	cm√Hz/W	8 to 14 μm, 1Hz, 1Hz BW	100
(typ)	2.11 x 10 ⁸			
Operating Voltage (min)	3	VDC	V+ to Gnd	104
(max)	15			(4.1.c)
Operating Current (min)	3	μA	RS=100kΩ	104
(max)	12			(4.1.c)
Offset Voltage (min)	0.3	V	RS=100kΩ	106
(max)	1.2			Section B
Output Impedance	<RS	Ω		
Thermal Breakpoint f _T (typ)	0.25	Hz		102
Electrical Breakpoint f _e (typ)	0.12	Hz	RL=6.5 x 10 ¹⁰ Ω	102
Recommended Operating Temperature	-10 to +50	°C	Functional	
Storage Temperature	-55 to +125	°C	ΔT<50C ⁰ /min	
Output Protection	Do not exceed a maximum drain current of 50 μA			

Characteristics at 25°C, with -3 filter, V+= 5 VDC, RS=100kΩ unless otherwise stated. Data is established on a sample basis and is believed to be representative.

For best results, the following precautions and recommendations should be observed. (See ELTECdata #101):

Mounting: Avoid mechanical stresses on case and leads.

Soldering: Detectors must be hand soldered to minimize the chance of destroying the internal components. Avoid machine or hot air soldering. Leave a minimum lead length of .250 inch (6.35mm). When soldering to detector leads, use a heat sink between the case and leads. Beware that the new RoHS compliant solders require a higher soldering temperature making heat sinking the detector extremely important.

Static Discharge: Protect detectors from electro-static charges.

Thermal Shock: Temperature changes and rate of change must be kept to a minimum (<50C^o/min.) to prevent damage.

Noise: As a resolution or lower information limit, noise is established not only by the detector. Other noise sources are:

- Radiated and conducted RF signals
- Subsequent amplification or signal conditioning stages
- Power supply noise
- Components, such as high value resistors and capacitors (tantalum and aluminum electrolytic)
- Mechanical contacts and weak solder joints
- Shock and vibration excited microphonics
- Outside thermal influences on the detector other than the desired infrared input, i.e. drafts

All of these noise sources should be considered carefully when the information signal is <1mV.

Light Leakage: Slight sensitivity to visible light leaking through the glass-to-metal seal on the base may be observed.

Optical Design: Use of a detector with a filter in an optical system may require consideration of the image displacement toward the filter. This displacement (s) caused by the insertion of a planoparallel plate (filter thickness = t; refractive index = N) is given by $s = (t/N)(N-1)$.

Transmission Characteristics of -3 Filter (HP7)

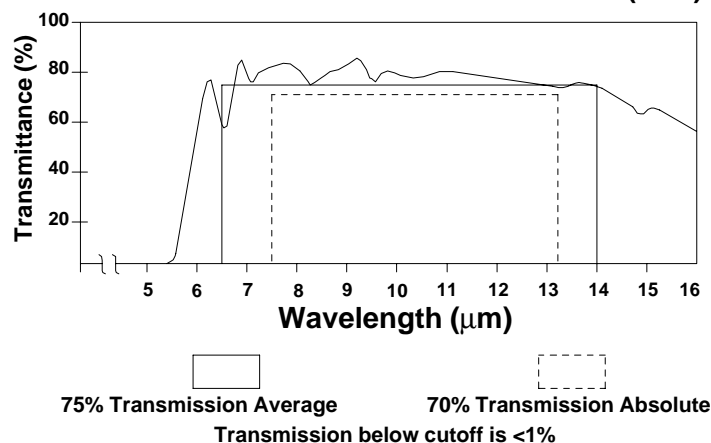

For information on other standard filters available, refer to ELTECdata #101.

NOTICE: The information provided herein is believed to be reliable. However, ELTEC Instruments, Inc. assumes no responsibility for inaccuracies or omissions. Due to industry components being incorporated into ELTEC's devices and ELTEC continually striving for product improvement, specifications may change without notice.



Worldwide Eltec Product Distribution and Free Technical Support:
Silverlight Ltd., Glaarnischstrasse 59, CH-8712 Staefa, Switzerland
info@silverlight.ch http://www.eltec.ch