

Model 420 Pyroelectric Laser Detector for UV/Vis/IR



Manufactured under one or more of the following U.S. patents: 3,839,640 - 4,218,620 - 4,326,663 - 4,384,207 - 4,437,003 - 4,441,023 - 4,523,095

Model 420 consists of a single lithium tantalate sensing element sealed into a TO-5 transistor housing with optical filter (optional).

A special element mounting technique is used to heat sink the sensing element, allowing detection at high power levels.

Fast pulse resolution is possible with low value (50Ω) load resistors. An integrating mode is achieved with high impedance converters like the ELTEC Model 320 Impedance Converter (inquire). For more information, see ELTECdata # 109. Two basic circuits are shown below.

Applications

- Laser Pulse Profile Studies
- Pulse Energy Measurements
- Useful with Monochromatic, Tunable or Multi-Laser Systems
- Laser Power Monitoring (when used with a beamsplitter)
- Millimeter Wave Studies
- UV Laser Detection

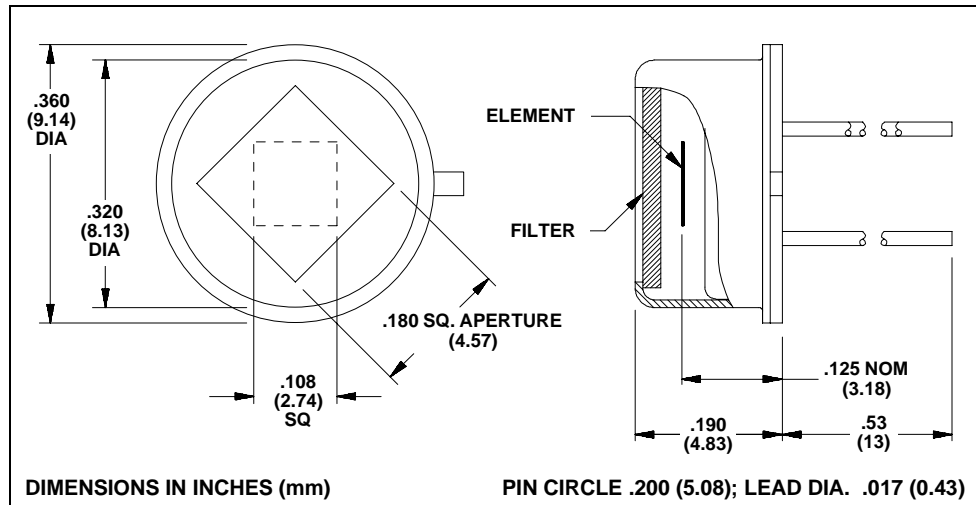

Characteristics	420	Unit	Test Conditions	ELTECdata Reference
Detector Type	Single			
Element Size	2.7 x 2.7	mm		
Optical Bandwidth	0.1 to 1,000	μm	Various Filters	101
Capacitance (min)	29	pF		
Capacitance (max)	44	pF		
Responsivity ¹ (typ)	1.3	V/W	10.6 μm , 100 Hz	
Current Responsivity (typ)	.25	$\mu\text{A/W}$		
Element Impedance (typ)	$> 5 \times 10^{12}$	Ω		
Thermal Breakpoint f_t (typ)	5	Hz		102
Electrical Time Constant τ_e (typ)	2	ns	$R_L = 50 \Omega$	102
Responsivity vs. Temperature (max)	+0.2	%/ $^{\circ}\text{C}$		104 (3.5)
Incident Power Limit ² (max)	5	W/cm ²	Call for Information	109
Recommended Operating Temperature	-55 to +125	$^{\circ}\text{C}$	Functional	
Storage Temperature	-55 to +125	$^{\circ}\text{C}$	$\Delta T < 50^{\circ}\text{C}/\text{min}$	
Curie Temperature	610	$^{\circ}\text{C}$		
Output Protection	Short output leads together if ΔT exceeds $50^{\circ}\text{C}/\text{min}$			

Characteristics at 25 $^{\circ}\text{C}$, with no filter

Data is established on a sample basis and is believed to be representative.

¹Integrating mode load resistor $R_L = 5 \times 10^6 \Omega$.

²Dependent on pulse width, power & duty cycle.

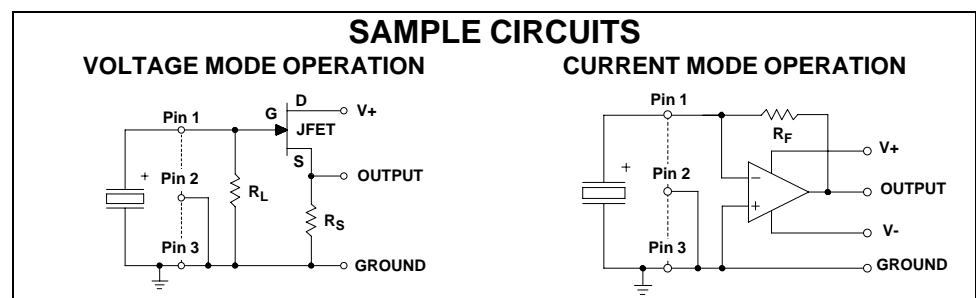
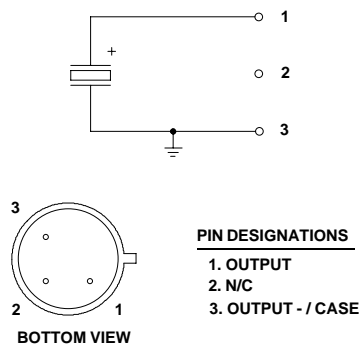

Field-of-View: Approximately 110° (50% power points)

For best results, the following precautions and recommendations should be observed. (See ELTECdata # 101):

Mounting: Avoid mechanical stresses on case and leads.

Soldering: Detectors must be hand soldered to minimize the chance of destroying the internal components. Avoid machine or hot air soldering. Leave a minimum lead length of .250 inch (6.35mm). When soldering to detector leads, use a heat sink between the case and leads. Beware that the new RoHS compliant solders require a higher soldering temperature making heat sinking the detector extremely important.

Static Discharge: Protect detectors from electrostatic charges.

Optical Filter: This Model can be used with any standard ELTEC detector filter or used without a filter. For more information, please refer to ELTECdata # 101.

Light Leakage: Slight sensitivity to visible light leaking through the glass-to-metal seal on the base may be observed.

Noise: As a resolution or lower information limit, noise is established not only by the detector. Other noise sources are:

- Radiated and conducted RF signals
- Subsequent amplification or signal conditioning stages
- Power supply noise
- Components, such as high value resistors and capacitors (tantalum or aluminum electrolytic)
- Mechanical contacts and weak solder joints
- Shock and vibration excited microphonics
- Outside thermal influences on the detector other than the desired infrared input, i.e. drafts

All of these noise sources should be considered carefully when the information signal is $<1\text{mV}$.

Optical Design: Use of a detector with a filter in an optical system may require consideration of the image displacement toward the filter. This displacement (s) caused by the insertion of a planoparallel plate (filter thickness = t; refractive index = N) is given by $s = (t/N)(N-1)$.

NOTICE: The information provided herein is believed to be reliable. However, ELTEC Instruments, Inc. assumes no responsibility for inaccuracies or omissions. Due to industry components being incorporated into ELTEC's devices and ELTEC continually striving for product improvement, specifications may change without notice.



Worldwide Eltec Product Distribution and Free Technical Support:
Silverlight Ltd., Glaernischstrasse 59, CH-8712 Staefa, Switzerland
info@silverlight.ch <http://www.eltec.ch>

©ELTEC INSTRUMENTS