

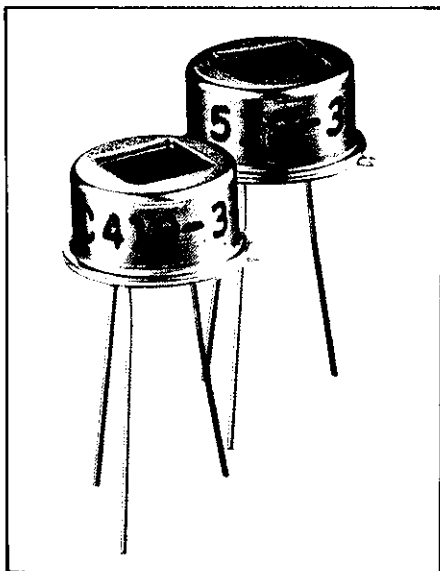

419/519 Parallel Opposed Dual Pyroelectric IR Detector with Source Follower

Manufactured under one or more of the following patents:
4,218,620 4,326,663 4,441,023 3,839,640



Model 419 consists of two physically separate lithium tantalate sensing elements and a FET source follower sealed into a TO-5 transistor housing with optical filter. It is identical to Model 4192 except that it has a higher offset voltage.

The sensing elements are connected electrically in a parallel opposed dual (POD) configuration for common mode signal cancellation. Signals from radiation falling on both active areas simultaneously will be cancelled, whereas a defined beam passing from one element to the next will produce two pulses: one positive and one negative.

A source resistor, 47 K Ω or greater is needed to set the JFET drain current.

Model 519 is a lower cost alternative selected to a higher noise tolerance.

Applications

- Intrusion Detection
- Lighting Control
- Robotics
- Motion Sensing
- Automatic Door Control
- Safety Warning

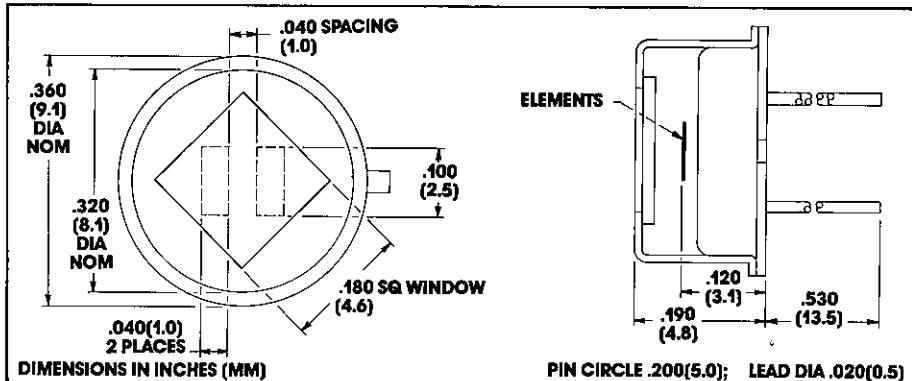
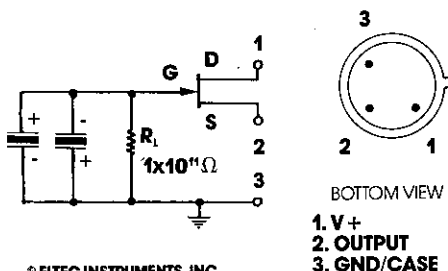

Characteristics	419	519	Unit	Test Conditions	ELTECdata Reference	
Detector Type	POD	POD	—			
Element Size	1.0 x 2.5	1.0 x 2.5	mm	nominal, each		
Element Spacing	1.0	1.0	mm	nominal		
Responsivity (Each Element)	min typ max	2000 2700 3500	2000 2700 3500	V/W	8 to 14 μ m@1Hz	
Common Mode Rejection Ratio	min typ	5:1 15:1	5:1 15:1	—	8 to 14 μ m@1Hz	
Noise	typ max	15 27	30 54	μ V/ \sqrt Hz	1.0Hz p-p (1 minute)	
NEP	typ max	1.4×10^{-9} 3.4×10^{-9}	2.8×10^{-9} 6.8×10^{-9}	W/ \sqrt Hz	8-14 μ m @1Hz, BW 1Hz	100
D*	min typ	0.4×10^8 1.0×10^8	0.2×10^8 0.5×10^8	cm \sqrt Hz/W	8-14 μ m @1Hz, BW 1Hz	100
Operating Voltage	min max	3 15	3 15	V	V _o to Gnd	104 (4.1.c)
Operating Current	min max	0.1 80	0.1 80	μ A		104 (4.1.c)
Offset Voltage	min max	0.4 2.5	0.4 2.5	V	R _s = 22K Ω	104 Fig. 4
Offset Voltage	min max	0.65 3.1	0.65 3.1	V	R _s = 100K Ω	104 Fig. 4
Output Impedance		20	20	K Ω		
Thermal Breakpoint f _r	typ	0.2	0.2	Hz		102
Electrical Breakpoint f _e	typ	0.05	0.05	Hz	R _L = 1×10^{11} Ω	102
Recommended Operating Temp.		-10 + 50	-10 + 50	$^{\circ}$ C		
Responsivity vs. Temperature	max	+0.2	0.2	%/ $^{\circ}$ C	Unity Gain Circuit	104 (3.5)
Incident Power Limit	max	0.2	0.2	W		
Pressure Sensitivity	max	200	200	μ V/mbar	Step Response	
Microphony	max	50	50	μ V/g	10-1000Hz	104 (3.9)
Package Sealing	max	10 ⁻⁸	10 ⁻⁸	cm ³ /sec	Helium	
Storage Temperature		-55 + 125	-55 + 125	$^{\circ}$ C	Δ T < 5 $^{\circ}$ C/minute	

Characteristics at 25 $^{\circ}$ C, with -3 Window, V_D = 5 VDC, R_S = 100K Ω unless otherwise stated. Data is established on a sample basis and is believed to be representative.

FIELD OF VIEW

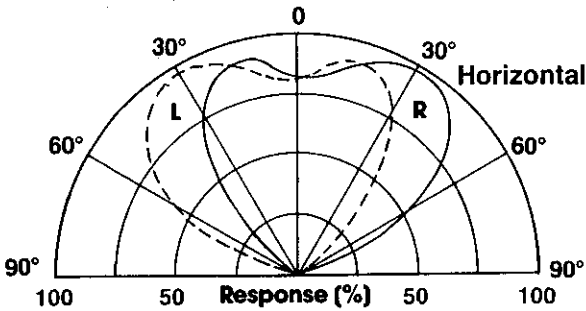
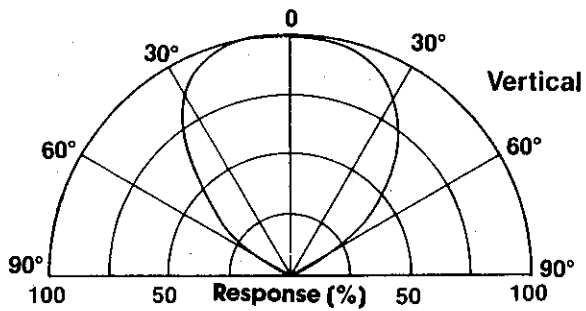

L - Left Element R - Right Element

For -3 window only. For other windows, consider refractive index and thickness.

For best results, the following precautions and recommendations should be observed. (See ELTECdata #101):

Mounting: Avoid mechanical stresses on case and leads.

Soldering: Use minimum heat and heat sink between case and leads. Leave minimum lead length of .250 inch (6.0mm). DO NOT MACHINE SOLDER.

Static Discharge: Protect detectors from electrostatic charges.

Thermal Shock: Temperature changes and rate of change must be kept to a minimum (<5°C/min.) to prevent damage.

Transmission Characteristics of -3 Window (HP-7)

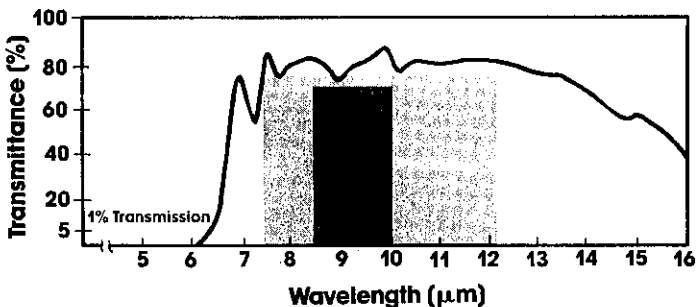

75% Transmission Average 70% Transmission Absolute

For information on other standard windows available, refer to ELTECdata #101.

FREQUENCY RESPONSE

(Each element)

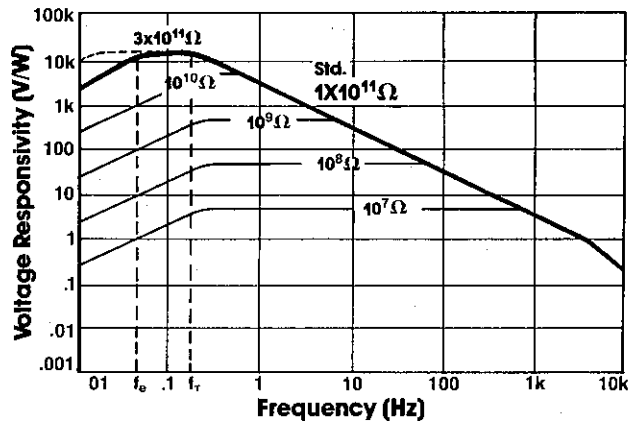

The voltage response of this detector is dependent on the pulse rate or equivalent frequency of input. The frequency response of the detector can be linearized by using a lower value resistor, but at the expense of a lower responsivity and a lower D^* . Load resistor values other than the standard $1 \times 10^{11} \Omega$ can be specified.

Noise: As a resolution or lower information limit, noise is not established only by the detector. Other noise sources are:

- Radiated and conducted RF signals
- Subsequent amplification or signal conditioning stages
- Power supply noise
- Components such as high value resistors and tantalum or electrolytic capacitors
- Mechanical contacts and weak solder joints
- Microphonics or vibration
- Outside thermal influences on the detector other than the desired infrared input, i.e. drafts.

All these noise sources should be considered carefully when the information signal is <1mV.

Optical Design: Use of a detector with a window in an optical system may require consideration of the image displacement toward the window. This displacement ($= s$) caused by the insertion of a planoparallel plate (window thickness = t ; refractive index = N) is given by $s = (t/N) (N - 1)$.

Light Leakage: Slight sensitivity to visible light leaking through the glass-to-metal seal on the base may be observed.

Optical Bandwidth: The detector is sensitive in a range from 1.5 to 1000 μm depending on window used. For more information, see Eltecdata #101.



© ELTEC Instruments, Inc.

Download from the ELTEC Information Center at <http://www.silverlight.ch>

Updated Jan. 2002